



E.A.T. Sweden presents **The Art of the Overhead**, sept-oct 2005, copenhagen

**keynOHte speaker** Siegfried Zielinski(de) **perfOHrmances** Felix Kubin(de) & Wojtek Kucharczyk(pl), Mikkel Metal(dk), Mikomikona(de), Uglen Batman & Copyflex(dk), Katrin Bethge & "für diesen abend"(de), Seimi Nørregaard(dk), Raketa(se), Jean Pa(dk), Vaimous(se)

**exhibitiOHn** Mike Salmond(uk), Ventsislav Zankov(bu), Lasse Lau(dk) & Anthony Graves(us), Rebecca Arthy(dk), Barbara Sterk(hu), Martin Conrads and Ingo Gerken(de), Bring Out The Garbage(dk/no), Anna Beck(dk), Lars Nielsen(dk) Femmes Regionales(dk), Anders Morgenthaler(dk), Aron Fleming Falk (se), Monix Sjölin (se) Vania Valkova(bu), Jonas Elfversson(se), Vanja Larberg(se), Louise Griffen(us), Pia Skoglund(se), Johan Holtzberg(se), Charlotte Troidahl(dk), Claus Ejner(dk), Andrei R. Thomaz(br), Rebekkah Palov(us), Otto von Busch(se), Harro Schmidt(de), Josh Berthwistle (can), Edward Slopek(can)



Harro Schmidt (de) - Sealife II



## Christian Faubel (de) - Overheadbots

Overheadbots live on overheads, a bit like parasites they sit on top of the overhead and convert its light into their proper motion. The overheadbots are completely autonomous, all their energy is delivered by the overhead. The whole system is like a little ecosystem and works once the overhead is turned on without any further intervention. The projected screen is like a 2 dimensional window to this world on the overhead projector, a world with real collisions, and unforeseeable events. On the other side the screen can also be seen as a an animated display, where color patches move around and form an ever-changing image.

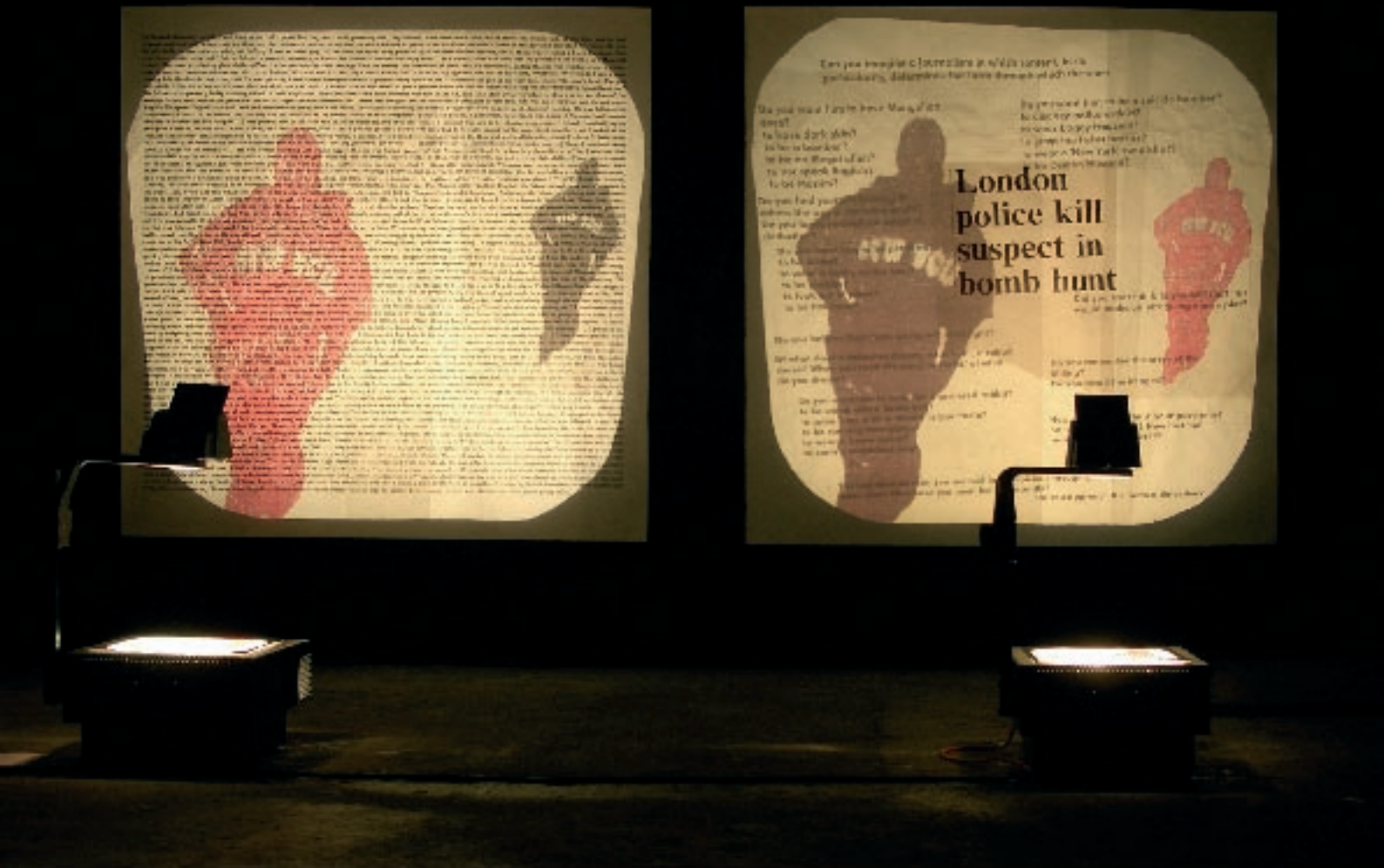

Lasse Lau & Anthony Graves (dk / us) Menezes/Text

Menezes/Text literally and openly interpellates the viewer through a series of questions superimposed upon a collage of statements collected from newspaper articles regarding Jean Charles de Menezes, the Brazilian killed by London police on July 22nd 2005. In the work we attempt to open questions regarding the way in which the media colludes with authority in producing and spreading suspicion among the general public. To what extent does the role of mass media produce us as individuals, and to what degree does it produce others for us? To what extent do we, as individuals, have agency over our own suspicions? Lurking in these questions is the opposition between individual agency and the unconscious influence of the media apparatus. In this work, the illuminated square of the overhead projector provided us with a space to exercise an artistic agency (through the necessarily limited means of an outmoded technology) over a text that both preceded us and is still being written.



Aron Fleming Falk - [www.fumca.net](http://www.fumca.net)



## The Art of the Overhead Archive

Mike Salmond(uk), Ventsislav Zankov(bu), Rebecca Arthy(dk), Barbara Sterk(hu), Martin Conrads and Ingo Gerken(de), Bring Out The Garbage(dk/no), Anna Beck(dk), Lars Nielsen(dk) Femmes Regionales(dk), Anders Morgenthaler(dk), Monix Sjölin (se) Vania Valkova(bu), Jonas Elfversson(se), Vanja Larberg(se), Louise Griffen(us), Pia Skoglund(se), Johan Holtzberg(se), Charlotte Troidahl(dk), Claus Ejner(dk), Andrei R. Thomaz(br), Rebekkah Palov(us), Otto von Busch(se), Josh Berthwistle (can) and Edward Slopek(can).



### Katrin Bethge & Für diesen Abend (de) Im Ohr brennt noch Licht

Katrin Bethge projects lights, colour, abstract forms, textures and pictures on walls, rooms or urban environments accompanied by the sound of für diesen abend developing a kind of abstract storytelling, a life-made hand-made film, while ordinary rooms lose their origins and change places or different ages.

[www.katrinbethge.de](http://www.katrinbethge.de) / [www.tausend-fuessler.de](http://www.tausend-fuessler.de)



### Siegfried Zielinski (de) - Hide & Show: A Short Geneology of Projection

Siegfried Zielinski, is Founding Director of the Academy of Media Arts in Cologne, where he is Professor of Media and Communication Studies. With publications like "Audiovisions" he is a founder of the field of media archaeology, and is developing a workshop for a variantology of the media. He has published more than a dozen books and many articles. His Deep Time of the Media is forthcoming from MIT Press in November.



## Felix Kubin & Wojtk Kucharczyk (de / pl) - Territerroritorium

Felix Kubin and Wojtek Kucharczyk share a passion for noise and electro-pop in vitro. In the piercing laboratory of the Syndikat für Gegenlärm (syndicate for counter-noise), they dissolve the border between Germany and Poland in order to skirmish a sound-battle in between, in Nobodyland. Whilst looting one's own cultural trash, everything that utters sonically, is brought onto the stage of international understanding, from talking crosswalks to Slav dogs' barking, to anthems without bottom brackets. Prejudices rage in the German-Polish forests. But anyway, Kucharczyk and Kubin act in a sense of punk rather than in diplomacy: First shout, and don't regret.



## Mikomikona (de) Fourier-Tanzformation I+II

With the piece *Fourier-Tanzformation I+II* mikomikona present a physical-semiotic experiment. In this investigation, we make use of two overhead projectors as sound devices. To accomplish this we layer several transparencies with raster patterns, flickering interferences are produced through shifting of the layers. Parallel to the projection, we capture these interferences with small b/w video cameras and transform the video signal into acoustic events. We implement our image-sound-converter, a small self-developed hardware device which eliminates the video's sync signal. The spectators see the two projections of black & white moiré patterns while simultaneously hearing the sound these patterns perform. What you see is what you hear. Fine moiré lines produce high tone, wider lines result in lower tone pitches. With small motors we create visual and acoustic rhythmic structures. Mikomikona is dispensing with any digitalisation. This ensemble of analogue techniques represents an opto-electronic synthesizer with two crossed outputs: image and sound. [www.zuviel.tv/mikomikona.html](http://www.zuviel.tv/mikomikona.html)

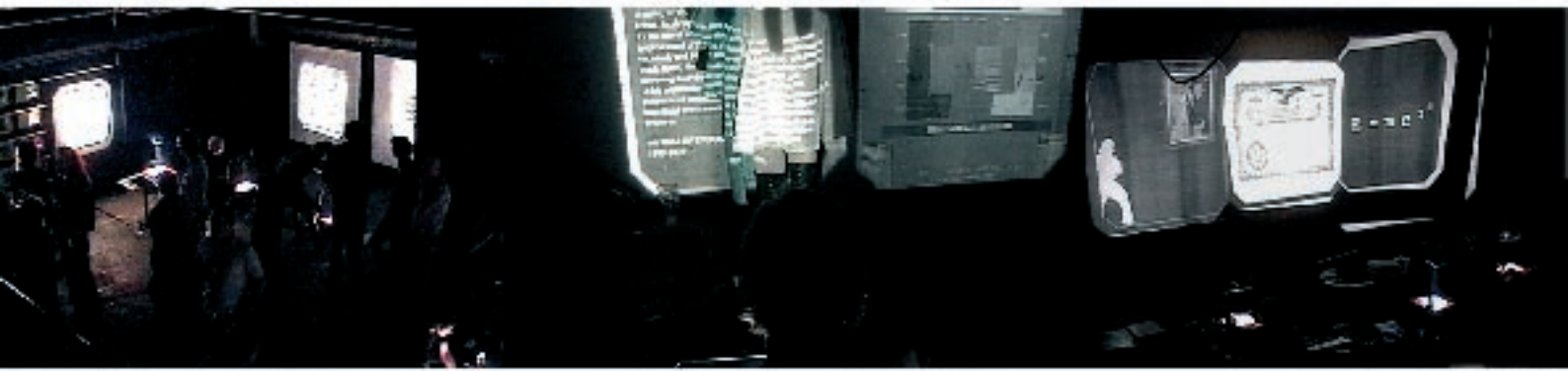

## Uglen Batman & Copyflex (dk) Copy this Idea

The performance deals with information flows and the differences and similarities between the analogue and the digital domains' influence on these flows. We take as our point of departure two dying machines: the overhead projector and the Xerox machine. The performance revolves around a flow of transparencies that is passed on by a chain of overhead operators. The rhythm of the performance is determined by a monotonous soundtrack.

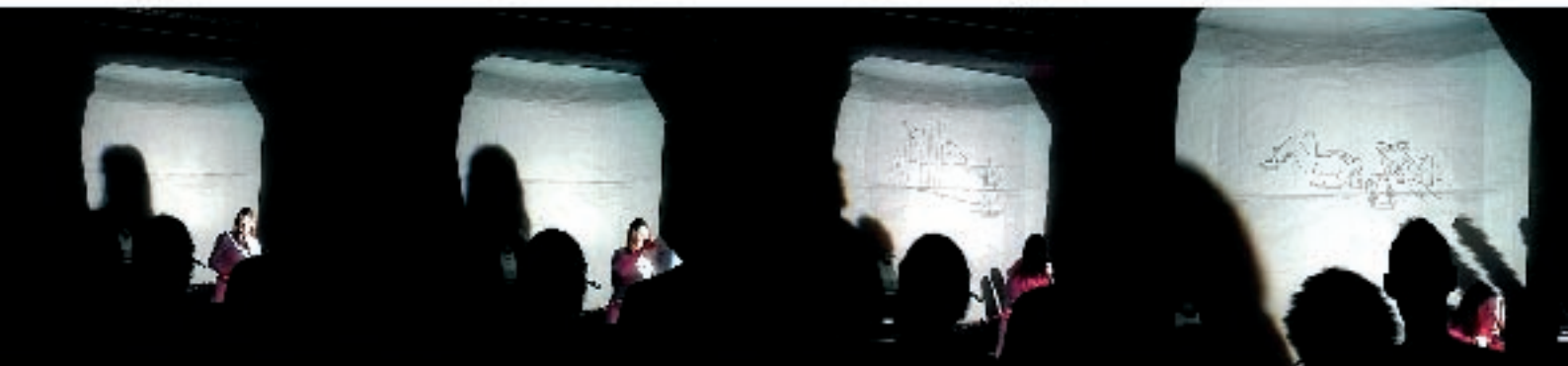

Seimi Nørregaard (dk)

Performance artist, writer, poetry performer and choreographer. Seimi Nørregaard creates her performances with text, visual and phonetic images.

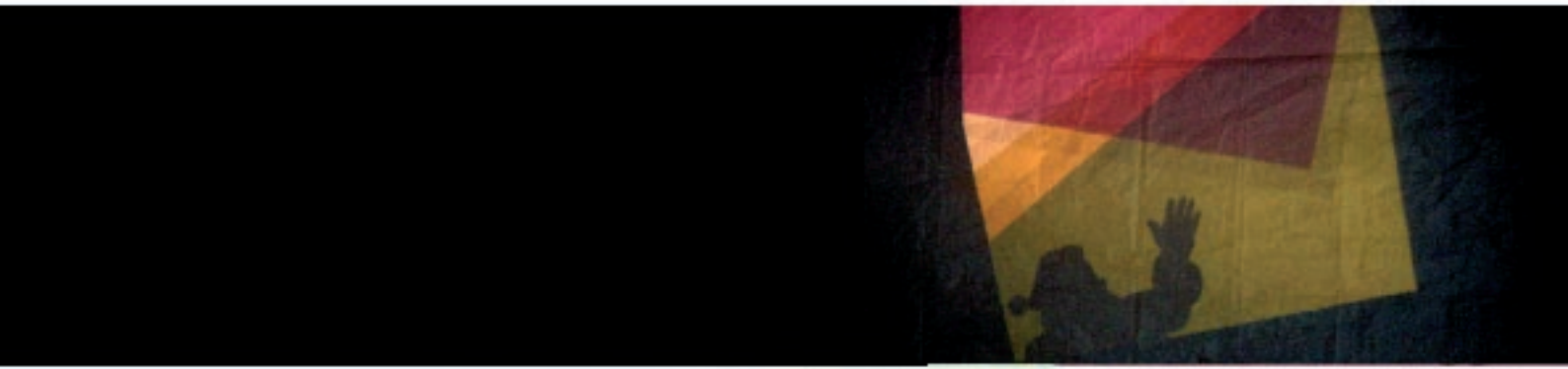

Jean Pa (dk)

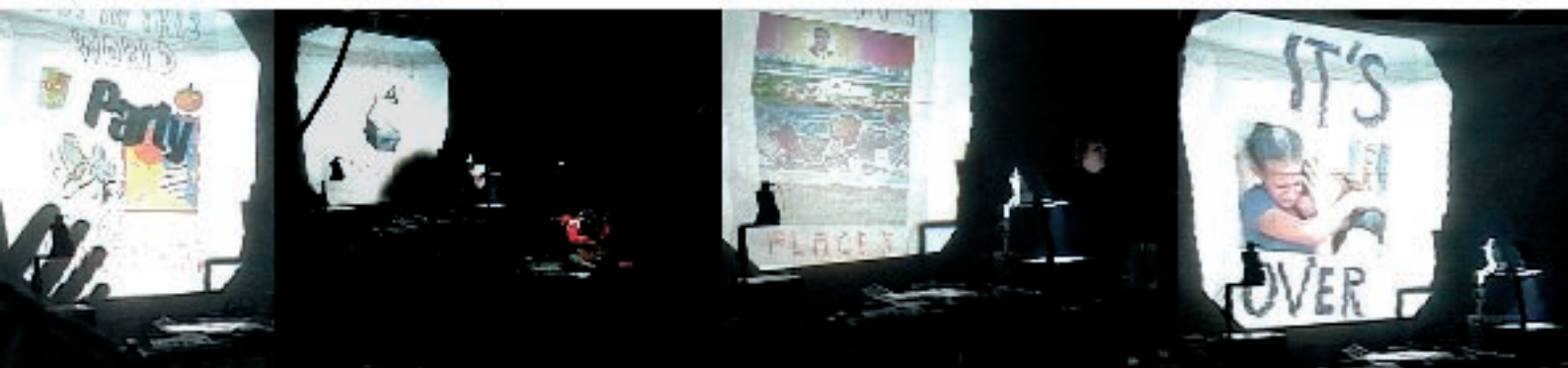

### Oliver Hangl & Johannes Grenzfurthner/Monochrom (at) - Farewell to the overhead

Austrian performance artists Oliver Hangl and Johannes Grenzfurthner, front-man of artist group 'monochrom' team up for a short pop-performance paying tribute to a dying media. Each of them well equipped with an overhead machine, they sing the praises to an apparatus standing for knowledge and harmony, visualizing its possible uses and abuses in the past and the future - a crispy pop song depicting the magic and loss, mixing nostalgia, individual memories and - last but not least - hope, a somewhat ambiguous farewell to the overhead!

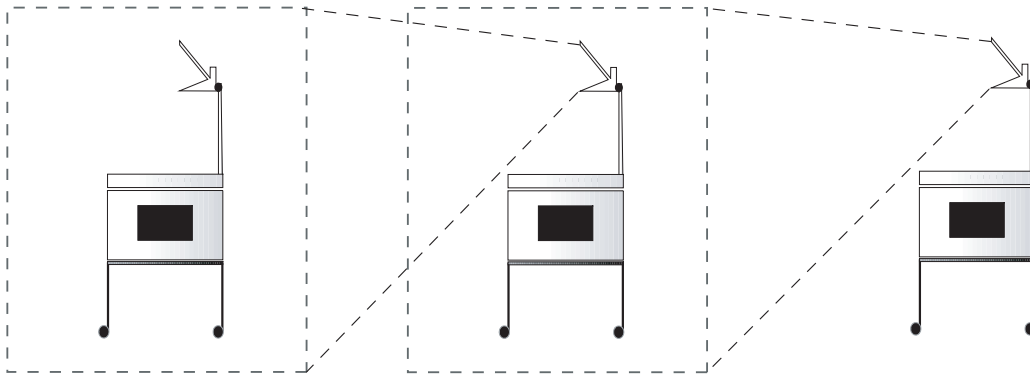

**The Art of the Overhead** - festival for forgotten media - CPH/DK, sept-oct 2005

### About E.A.T. Sweden – Experiments in Art & Technology

The Art of the Overhead is brought to you by EAT Sweden, a group of artists and engineers based in Sweden and Denmark that in its name pays homage to the projects of the late pioneer Billy Klüver and which works with a critical rethinking of the relationship between art and technology.

Thanks to: [www.kontorzonen.dk](http://www.kontorzonen.dk), 3M, Sparbanksstiftelsen Skåne, K3 - School of Arts & Communication Malmö University

[info@overheads.org](mailto:info@overheads.org) / [www.overheads.org](http://www.overheads.org) / [www.eat-sweden.se](http://www.eat-sweden.se)